



FOODSERVICE

# Owner's Manual

Read And Save These Instructions



## ***BarBoss<sup>®</sup> MP*** ***Drink Machine MP***

Maximum Performance Commercial Blender

All Models

# *Important Safeguards*

1. Read all instructions.
2. To protect against risk of electrical shock, do not put motor base in water or other liquid.
3. Close adult supervision is necessary when appliance is used by or near children.
4. Unplug the power cord from the wall outlet when the Vita-Mix® blender is not in use, before disassembling, putting on or taking off parts, and before cleaning, other than washing the container.
5. Never contact moving parts, especially the blades.
6. Do not operate any appliance with a damaged cord or plug or after the appliance malfunctions or is dropped or damaged in any manner. Call Vita-Mix Service, (800) 4DRINK4, (800-437-4654) or (440) 235-0214 at once for possible replacement, examination, repair, electrical or mechanical adjustment. If you live outside the United States, contact your local Vita-Mix Distributor, or phone the Vita-Mix International Division at +1 (440) 235-5494 or email [international@vitamix.com](mailto:international@vitamix.com) for a distributor in your country.
7. The use of attachments not recommended or sold by Vita-Mix Corporation may cause fire, shock, or injury.
8. **Do not use outdoors.**
9. Do not let the power cord hang over edge of table or counter, or touch hot surfaces.
10. Keep hands and utensils out of container while motor is running to prevent the possibility of severe personal injury and/or damage to the Vita-Mix blender. A rubber scraper may be used, but only when the Vita-Mix blender is not running. With the flexible rubber lid in place the tamper may be used while motor is running.
11. **WARNING: Blade is sharp. Handle carefully.**
  - Never try to remove blade while container is sitting on the motor base.
  - Do not operate with loose, nicked or damaged blade - replace immediately.
  - To reduce the risk of personal injury, never place blade assembly on motor base without blender container properly attached.
12. The maximum capacity is equivalent to the ounces (liters) listed on the container, i.e. 32 oz. (900 ml) and substantially less with thick mixtures.
13. Container should not be more than 2/3 full when the tamper is left in place while blending. Do not exceed 30 seconds of continuous blending with tamper in place.
14. **CAUTION:** Cooling problems resulting in thermal shut-off and eventual motor damage may result if machine is operated in sound chambers other than those approved by Vita-Mix.
15. Always operate the Vita-Mix blender with a lid in place.
16. **CAUTION:** On all units with timers the light in the front panel START/STOP switch, when lit, indicates the power to blender is ON and blender could start. Turn power OFF, or unplug the machine before touching movable parts.

# Important Safeguards

17. **WARNING:** When processing hot liquids:

- The 2-part latching lid must be securely in place. This allows steam to escape naturally, and will prevent the lid from coming off when the machine is turned on.
- Do not start on HIGH speed. Always start hot liquids on LOW speed then switch to HIGH speed while the machine is running.
- Use caution with hot liquids. Spraying from under the lid plug can occur, or escaping steam may cause scalding.
- Do not process hot liquids with the Vita-Mix non-latching lid.

## Save These Safety Instructions

Enjoy the safety of this grounded appliance. The Vita-Mix blender's U.S. power cord comes equipped with a three-prong (grounding) plug which mates with a standard three-prong wall outlet (Figure A). This cord will vary for countries outside the United States.

Adapters (Figure B) are available for two-prong outlets. Do not cut or remove the third (ground) prong from the plug or power cord.

Consult your electrician if you are not sure if the wall outlet is grounded through the building wiring. With a properly grounded two prong wall outlet, ground the machine by attaching the tab on the adapter to the wall outlet cover by means of the screw in the center of the cover (Figure B).



**THREE PRONG  
ADAPTERS  
ARE NOT TO  
BE USED IN  
CANADA.**

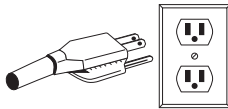

Figure A

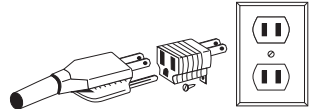
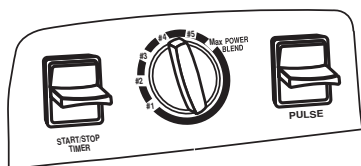

Figure B

# Control Panel



**Note on Timers:** Stop mid cycle with START/STOP switch, not the ON/OFF switch. If the ON/OFF switch was used, wait 30 seconds for power to recycle and the timer to reset before resuming operation.



## **BarBoss® MP & Drink Machine MP Model**

**ON/OFF switch.** Located on the front of the machine below the switch panel, controls the power to the machine. With the machine plugged in, switch the machine to ON to ready the machine for blending. Shut OFF power switch at night or whenever the machine will be left unattended.

**START TIMER switch.** This is a lighted switch. When light is lit power is ON. Depress START TIMER switch to activate timer setting and again to stop midcycle.

During operation, you may interrupt timer by pressing START/STOP switch.

**TIMER DIAL.** Allows user to select a number of timed settings. Increments on timer are approximate seconds. Timer is activated *only* when the power switch is ON. Blender will shut off automatically at the end of the pre-set time.

**PULSE switch.** Pulse button can only be used when the power switch is ON. The PULSE switch can be used to quickly refresh product in the container by depressing the switch and holding down as long as needed.

**NOTE:** Switches will become sticky from use. Use a wet cloth or sponge to flush and clean in the groove around the water-shielded switches. You may also lightly spray the surface around the switches with an all purpose cleaner (such as Cinch® or 409®) and work the switches back and forth a few times to loosen any dried residue under switch. Leaving switches sticky will damage or burn out the switches.

# Lid Assembly

**NOTE:** Outside the United States and Canada, your machine may come with a different container configuration.

## **Two-Part Lid**

### **32 oz. (900 ml) Maximum Performance Container (MP32)**

The two part lid is easy to clean and easy to put on, take off and seal.

- To remove a fully latched lid, lift the two tabs and pull upward and off.
- Twist the center lid plug to fasten or remove.

**NOTE:** Older 48 oz. (1.4 L) and 64 oz. (2.0 L) Vita-Mix container will work on the BarBoss or Drink Machine MP. The MP32 will not work on older Vita-Mix Machines. Call Vita-Mix or your distributor for more information.

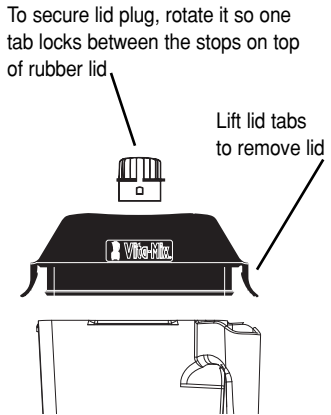

**Figure A**

## **One Piece Lid (optional)**

### **32 oz. (900 ml) Maximum Performance Container (MP32)**

The one piece lid is easy to clean and easy to put on, and take off and seal.

- There is no lid plug for this lid.
- Add ingredients through port on top.



**Figure B**

**NOTE:** To make new lids easier to insert and remove, rub a light coating of cooking oil around bottom where it seals. Place it in container for several minutes, remove and lightly wipe oil off lid.

# General Instructions

## BarBoss® MP & Drink Machine MP Instructions

1. Set the container on the motor base by aligning it over the centering pad anchored to the base. (Motor must be completely stopped before positioning container). Containers are not to be used for hard, dry materials. Avoid running your machine with the container empty.
  2. Place liquids and soft foods in the container first, solid items and ice last. Prepare food by cutting or breaking into 1-3 inch (3-8 cm) pieces. Frozen fruit should be as small as practical.
  3. Always use lid when blending. If blending hot ingredients, the lid must be securely in place. When processing hot liquids, DO NOT use a non-latching lid.
  4. Press ON/OFF switch to ON. Activate the timer by selecting the desired setting on the dial and then depressing the START/STOP TIMER switch on the left.  
**NOTE:** Each setting on the dial (#1 - #5 and MAX Blend) is an increase in time and speed. Your own testing will determine what setting will work best for your drinks.
    - 4a. If mixture stops circulating, you have likely trapped an air bubble. Either insert the tamper through the lid while blending, or stop the motor remove the container from the base and stir or scrape the mixture from the sides of container into the center using a rubber spatula to press any air bubbles away from the blades. Replace the lid and continue blending.  
**Note:** START/STOP TIMER switch on your machine is lit when power is ON. Avoid moveable parts. The timer stops working if machine is overloaded on low speed. Reset the machine by turning power OFF for 15 seconds.
-  **Warning: If you detect a change in the sound of the machine or if a hard or foreign object comes into contact with the blades, do not serve the drink. Inspect your blade assembly for loose, nicked or missing parts. If parts are loose, missing, or nicked replace with new blade assembly. (See page 8.)**
- 4b. To prevent possible splashing, lightly rest your hand on the lid while turning the machine on (except when processing hot liquids).
  - 4c. Due to the blending speed of the machine, processing times are greatly reduced over standard machines. Until you become accustomed to the speed, watch your mixture carefully to avoid over-blending.
  - 4d. If stopping the machine mid-cycle, use the START/STOP switch, not the POWER switch. If the POWER switch was used, wait 30 seconds for power to recycle and the timer to reset before resuming operation.
5. After blender has been turned off, wait until blade comes to a complete stop before removing the lid or container from the motor base.

**Note:** The thermal protector shuts the motor off to protect it from overheating. To restart, wait for motor to cool down with the power OFF (up to 30 minutes). When this happens, review your processing techniques and your instructions. Your recipes may be too thick or have too much material in them.

Cooling may be quickened by placing the motor base in a refrigerator or a cool spot. Unplug first. To speed up the process try circulating the air with a vacuum or fan aimed at the bottom of the base. If the motor seems to be over heating (and the thermal overload protector has not turned the machine OFF), remove the container from the base. Set the timer for 20 seconds. Turn the machine ON and let the machine run for 20 seconds. Repeat this step 3 times for a total of 1 minute.

- 6. To use the PULSE switch on the Drink Machine MP blender:** Press ON/OFF switch to ON. With the container on the motor base depress the PULSE switch. Release the switch to turn off the motor.

# Blade Agitator Assembly

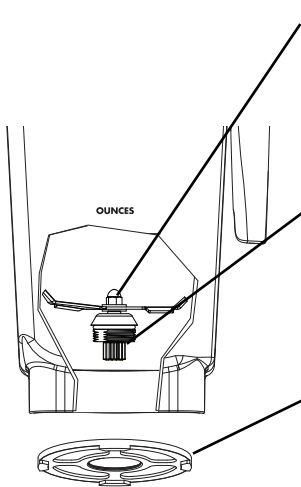

**Blade Agitator Assembly.** Blades are sharp; use caution when handling the blade. When inserting the blade assembly through the container bottom, align the flat sides. Gravity holds it in place while the retainer nut is tightened. Do not attempt to disassemble this part.

**Drive Spline.** Mates with drive socket on the motor base to turn the blade. Note: Removing and replacing your container while the coupling is still rotating will strip the drive spline “teeth”. (This part is NOT removable.)

**Retainer Nut.** Must be snug. Order the available retainer nut wrench for best results. (Refer to the diagram below to remove or replace.)



**Never use a blade assembly with loose, damaged or nicked components.**

## Blade Assembly Removal

**CAUTION: Do not remove blades unless absolutely necessary!**

At times, it may be necessary to give your blades additional cleaning. An easy-to-use blade assembly removal wrench (Item #15596) may be purchased through your Vita-Mix distributor. **Never attempt to take the blade assembly itself apart. This will void the warranty.**

Turn the container upside down and grip firmly. Insert retainer nut wrench in groove of retainer nut and rotate counterclockwise to loosen. Then grip blades with a cloth and remove retainer nut by hand.

### Replacing Blade Assembly

With the container upside down, grip blades with cloth, insert into the container bottom and align with flat sides of container opening. Place retainer nut on and hand tighten. Last, carefully turn clockwise until secure, using wrench. Do not force. If it is not tight enough, you will notice increased container noise.

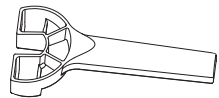

Retainer Nut Wrench

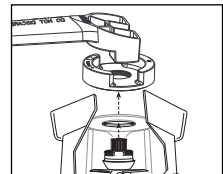

Retainer Nut Wrench in use.

# Tamper

The tamper prevents an air bubble from forming while blending. It is used when making frozen ice creams, pureeing fruits and vegetables, (or whenever your mixture requires it). It also permits you to push ingredients down around the blades while the Vita-Mix blender is running.

Tamper use:

- Use only with the lid in place and the center lid plug removed.
- The splash disc prevents the tamper from hitting the blades when inserted through the lid.
- Container should not be more than 2/3 full (just below the indicated maximum capacity for MP containers) when the tamper is left in place while blending.
- To avoid overheating, do not exceed 30 seconds of continuous blending with tamper in place.
- If thick mixtures stop circulating, you have likely trapped an air bubble. Insert tamper through the lid and stir to release it.
- Holding the tamper at an angle near the side and pushing towards the center will be more effective when creating a thicker, smoother drink.

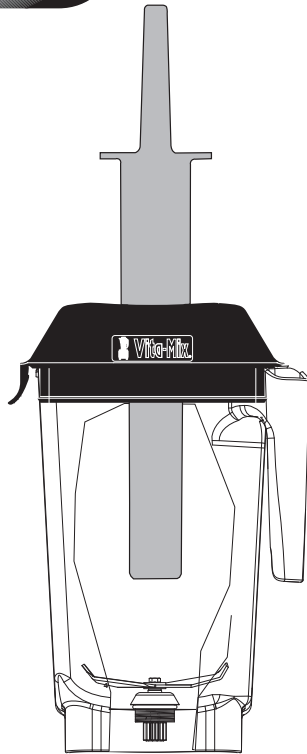

**\*NOTE:** Tampers have a small step on them. The step prevents the tamper from coming into contact with the blades in Vita-Mix polycarbonate containers. Tampers cannot be used with a one piece non-latching lid.

## Warning

**When processing hot liquids always:**

- Use caution; escaping steam or splatters may scald.
- Completely latch the lid; this will prevent expansion from blowing it off when the machine is turned on.
- Start on LOW speed then switch to HIGH speed. Never start on HIGH speed with hot ingredients.
- Do not process hot ingredients with a non-latching lid.

# Caring For Your Machine

## Care Note

To ensure that you get the longest possible life from your Vita-Mix product, we recommend the following products, when used as directed by the supplier:

### Cleaning Product

Solid Supra, Solid Power,.....	<b>Supplier</b> <b>Ecolab, Inc.</b> , St. Paul, MN (800) 352-5326 www.ecolab.com
Guardian Acclaim, Solid Guardian Plus, Solid Super Impact, Solid Insure	<b>Diversey</b> , Livonia, MI (800) 521-8140
Diverpak.....	<b>Klenzade Products</b> Division of Ecolab St. Paul, MN (612) 293-2165
Eclipse H2, Liqui-Safe L7	<b>Wesmar Company, Inc.</b> Seattle, WA (206)783-5344 www.wesmar.com
Acclean .....	<b>Anderson Chemical Co.</b> Litchfield, MN (800) 366-2477 www.andersonchemical.com
Poly-Brite	
Glow MB-1.....	
Lustre NC-25	
Lustre Plus	
PSRA 41-D, PSRA 41-E .....	
Liqui-Ware 1, Liqui-Ware MC	
D-Flex, Sur-Met	

### Rinse Aids

Solid Rinse Dry	<b>Supplier</b> Ecolab, Inc., St. Paul, MN (800) 352-8140 www.ecolab.com
Solid Brilliance	
Jet Dry, Rinse Dry	

### Destainer.....

NuWare	<b>Supplier</b> Diversey, Livonia, MI (800) 521-8140
--------	--

**NOTE:** Switches will become sticky from use. Use a wet cloth or sponge to flush and clean in the groove around the water-shielded switches. You may also lightly spray the surface around the switches with an all-purpose cleaner (such as Cinch® or 409®) and work the switches back and forth a few times to loosen any dried residue under switch. Dirty switches may burn out.

**ADDITIONAL NOTE:** Do not let mixtures, liquids and food products dry within the container. Rinse throughout use. Drying may lock around the blade and weaken/tear the bearings seal when restarted. Do not place containers in the freezer. Extremely low temperature combined with hot ingredients and/or the immediate rapid action of the blade may crack the container. Due to the nature of polycarbonates, microwaving and automatic dishwashing are not recommended. Follow the cleaning instructions on page 11.

# Care and Cleaning

## **Motor Base**

1. Unplug the power cord.
2. Wash outside surface with a damp, soft cloth or sponge, which has been rinsed in a mild solution of liquid dish soap (Ivory Liquid® or equivalent) in warm water. NEVER IMMERS MOTOR BASE IN WATER OR OTHER LIQUID.
3. Thoroughly clean switches so that they work freely. They will become sticky from use. Use a wet cloth or sponge\* to flush and clean in the groove around the water shielded switches. You may also lightly spray the surface around the switches with an all-purpose cleaner such as Cinch® or 409® and work the switches back and forth a few times to loosen any dried residue under switch.
4. Polish with a soft cloth.

**\*Note:** Be sure to wring excess water out of cloth or sponge when cleaning around the controls or any electrical part.

## **Lid**

Separate the lid and plug, then wash in warm soapy water. Rinse clean under running water and dry. Reassemble before use. (See page 5).

## **Container**

1. To clean: Fill pitcher 1/4 full with warm (110°F/43°C) water and add a couple drops of dish soap.\*\* Return container to motor base and firmly position the two part lid. Run machine for 30 seconds. Empty container. Repeat this step.
- \*\* **Note:** To prolong polycarbonate container life, Vita-Mix recommends using soaps with a low Ph balance, such as a manual pot and pan detergent. Due to the nature of polycarbonates, automatic dishwashing is not recommended.
2. Fill pitcher 3/4 full with warm (110°F/43°C) water (do not add soap). Return container to motor base and firmly position the two part lid. Run machine for 30 seconds. Empty container.
3. If any solid residue remains, remove the blade agitator assembly (see page 8) and wash all container parts in warm soapy water. Rinse and drain. Reassemble before next step.
4. To sanitize: If all solid residue is gone after step 2 or after completion of step 3, fill container 3/4 full with a sanitizing solution mix.\*\*\* Return container to motor base and firmly position the two part lid. Run machine on HIGH for 30 seconds. Empty container.
5. Return container to motor base and run machine empty for an additional 5 seconds. Do not rinse after sanitizing.

\*\*\* Recommended sanitizing solution: 1-1/2 teaspoons institutional or household bleach in 2 quarts (2 liters) water.

# Parts List

## BarBoss® MP & Drink Machine MP

**NOTE:** Outside the United States and Canada, your machine may come with a different container configuration. Contact your local Vita-Mix distributor for part numbers.

Item #	Part
#760	Tamper
#RBB162	Sound-reducing centering pad
PLS132	Variable speed control knob / timer control knob
#802	Drive socket
XDM039	Owner's Manual
#836	Heavy-duty retainer nut
#15577	Agitator assembly (MP Blades)
#15596	Retainer nut wrench
#15571	32 oz. (900 ml) polycarbonate Maximum performance container (MP32) with lid and lid plug
#15574	2-piece thermoplastic rubber lid for 32oz. (900 ml) maximum performance container (MP32)
#15570	32 oz. (900 ml) polycarbonate stackable Maximum performance container (MP32), ice blade & lid assembly
#15573	32 oz. (900 ml) polycarbonate stackable Maximum performance container (MP32) only

**\*Notice:** Other than the drive socket, blade assembly and retainer nut, this unit is not user serviceable.

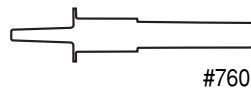
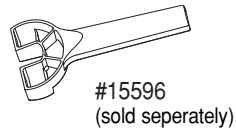
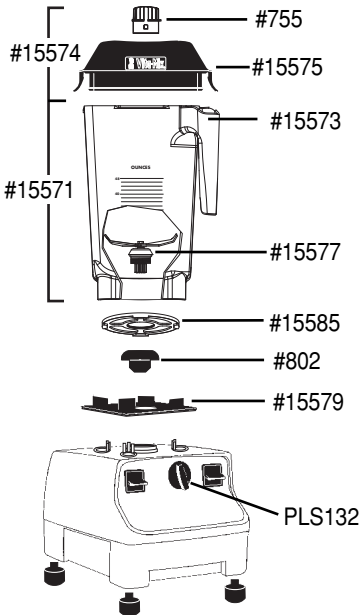

# Troubleshooting

## Top four problems you can fix on your own

### 1. Problem:

- increased vibration
- leaking from bottom of container
- increased container noise

### Solution #1:

Check blade assembly for loose, damaged or nicked components and replace.

### Solution #2:

Tighten retainer nut with screwdriver moving clockwise until it is snug. See p. 8.

### 2. Problem:

- Machine will not run.

### Solution #1:

Double-check to make sure power cord is firmly in power outlet.

### Solution #2:

Check to make sure switches are clean and moving freely.

### Solution #3:

The thermal protector may have turned the machine OFF. Turn power OFF for up to 30 minutes to reset. **Note:** Cooling may be quickened by placing the motor base in a refrigerator or cool spot. (Unplug first). To speed up the cooling process, try circulating the air with a fan or vacuum at the bottom of the motor base.

### 3. Problem:

- loud noise from blade area
- blades don't spin

### Solution:

Drive socket may be broken. Check for a fine crack down the center or worn teeth—replace with a new drive socket. (Item # 802). Instructions are included with part.

### 4. Problem:

- Machine will not run when START TIMER switch is activated.

### Solution:

Check ON/OFF switch to make sure the switch is in the ON position. **Note:** START TIMER switch is lit when power is on.

Timer stops working if machine is overloaded on low speed. Reset by turning power OFF for 15 seconds. Do not turn power OFF midway through a blending cycle. To interrupt cycle, press START/STOP TIMER switch one time. See page 4.

If you cannot fix your machine with these suggestions, technical help is available by calling 800-4DRINK4 (800-437-4654). If outside the United States and Canada, contact your local Vita-Mix distributor or phone the Vita-Mix International Division at +1 (440) 235-5494 or email [international@vitamix.com](mailto:international@vitamix.com) for a distributor in your country.

---

# Warranty

---

Vita-Mix Corporation warrants your Commercial Vita-Mix appliance to be free from defects in materials and workmanship for a period of three years from the date of purchase when used in accordance with the accompanying instruction booklet.

Provisions of this limited warranty are void if your Vita-Mix appliance has been subjected to obvious abuse, negligence, accident, alteration, or failure to follow operating instructions, or product exposure to abnormal or extreme conditions. Cosmetic changes such as discoloration of parts of the product in the hands of the user or the effects of the use of abrasive cleaners will not be warranted or considered defects. The cleaning or removal of food products along with any damage caused by allowing them to build up is not covered by this limited warranty. Warranty is void if the Vita-Mix blender is put into a sound reduction chamber that does not allow proper cooling.

In the event your Vita-Mix appliance needs service or repair covered by the terms of this warranty, please call the Vita-Mix Corporation for shipping instructions. The Vita-Mix blender must be sent in original or sufficient packaging.

This limited warranty is in lieu of any other warranty expressed or implied. No representative or any other person is authorized to make any other warranty or to assume any liability not strictly in accordance with the foregoing. This limited warranty gives you specific legal rights which may vary from state to state. Proof of purchase may be required to prove date of purchase.

**Outside the Continental United States and Canada other warranties may apply.** (Call or check with your local Vita-Mix distributor for details). In case of shipping damage, notify the shipper or carrier immediately. Outside the United States and Canada, contact your local Vita-Mix Distributor.

# Service Contract

**PLEASE NOTE:** The Service Contract outlined in the following paragraphs applies only to customers in the United States and Canada. Customers in all other countries should contact their local Vita-Mix® distributor for service details.

This Vita-Mix blender includes a 1-Year Service Contract effective from date of purchase. In the event your machine should need parts or repairs, covered under this Service Contract, call Vita-Mix customer service immediately for instructions. Proof of date of purchase may be required. This does not cover abuse, misuse, tampering, improper installation or extreme conditions.

The Vita-Mix Service Contract includes the following:

1. Only one extra drive socket - to facilitate simple repairs and prevent down time is included and packaged with each machine.
2. Additional drivers and tamper, unless defective, are not covered. **NOTE:** to determine if you have a defective part, please order a replacement part through Vita-Mix Customer Service and, when the new part arrives, return the old part in the same packaging. Vita-Mix will inspect the returned part and, if defective, issue a refund for the price of the new part. A part will be considered defective if no abuse or neglect was involved with its break. Non defective parts sent to Vita-Mix for inspection will not be returned if deemed unusable. Service Contract covers functionality of the machine but not abuse or lack of recommended maintenance.
3. In the continental United States, sender pays freight one way to Vita-Mix Corporation. The Vita-Mix Corporation will pay UPS ground freight charges to return the machine to the sender. Sender pays costs for special shipping requests. Outside Continental United States, other service contracts may apply.

Before returning this product for any reason, including repair, please, first contact our CUSTOMER SERVICE DEPARTMENT: (800) 4DRINK4, (800) 437-4654 or (440) 235-0214 to receive a "RETURN AUTHORIZATION NUMBER".

**Note:** Within the United States, Limited Warranty and Service Contract are honored directly through the Vita-Mix Corporation, Cleveland, Ohio USA. Non-warranty repairs can be performed by any CFESA service center. For machines sold in the USA, call Vita-Mix (800) 4DRINK4 (800-437-4654) or (440) 235-0214.

# Specifications

## **Dimensions:**

Height of Motor Base: 8-1/2" (21.25 cm)

- with 32 oz. (900 ml) polycarbonate maximum performance container (MP32) and lid: 18" (45.72 cm)
- with 32 oz. (900 ml) polycarbonate maximum performance container (MP32) without lid: 16" (40.64 cm)

32 oz. (900 ml) polycarbonate maximum performance container (MP32) with lid, no base: 10-3/4" (27.31 cm)

Dimensions: 8" W x 9" D x 18" H (20.3 cm x 22.9 cm x 45.72 cm)

Ship weight of machine: 13 lbs. (6 kg)

## **Power Requirements:**

Volts: 120 VAC

Volts: 220/240 VAC

Volts: 100 VAC (Japan)

Amps: 11.5

Watts: 750-850

Watts: 900

Hz: 50/60

Hz: 50/60

Hz: 50/60

**The instructions appearing in this Owner's Manual cannot cover every possible condition and situation that may occur. Common sense and caution must be practiced when operating and maintaining any appliance.**



**VITA-MIX® CORPORATION**  
**Foodservice Division**

8615 Usher Road, Cleveland, Ohio 44138-2103 USA

©2003 Vita-Mix Corporation. No part of this publication may be reproduced or transmitted in any form or by any means, electronic or mechanical, including photocopy, recording or any information storage and retrieval system without the written permission of the Vita-Mix Corporation.